

4

3

2

1

Part No	Description	Saddle Length
DGC/UNI/30MS	30mm Medium	130mm
DGC/UNI30/ML	30mm Medium	150mm
DGC/UNI/34/MS	34mm Medium	130mm
DGC/UNI/34/ML	34mm Medium	150mm

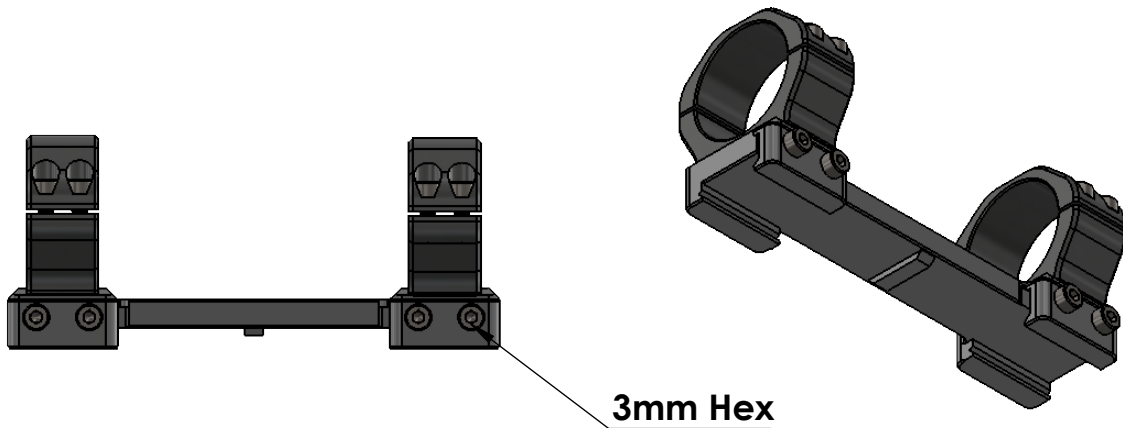
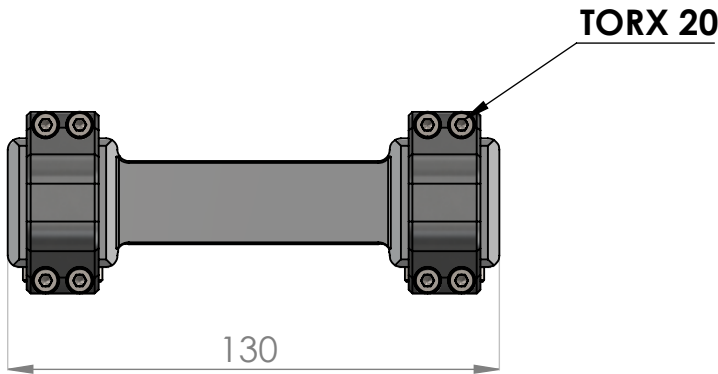

TORQUE SETTINGS	In/lb	Nm
Torx 20	25	2.8
3mm Hex	45	5.0

UNLESS OTHERWISE SPECIFIED: DIMENSIONS ARE IN MILLIMETERS SURFACE FINISH: TOLERANCES: LINEAR: ANGULAR:			FINISH: HARD ANODISE 40 MICRONS BLACK		DEBURR AND BREAK SHARP EDGES		DO NOT SCALE DRAWING		REVISION		
							DOLPHIN GUN COMPANY				
							Unimount				
DRAWN: AB			SIGNATURE:		DATE: 04/02/20		TITLE:				
CHK'D:							DWG NO.:				
APPV'D:							A4				
MFG:							SCALE: 1:2				
Q.A:					MATERIAL: AL6082 T6		SHEET 1 OF 1				
					WEIGHT:						

4

3

2

1

F

F

E

E

D

D

C

C

B

B

A

A