

4

3

2

1

| Part No | Description | Height |
|----------|-----------------|------------------|
| DGC/30M | 30mmMedium | Height 'A' =25mm |
| DGC/30H | 30mm High | Height 'A' =29mm |
| DGC/30EH | 30mm Extra High | Height 'A' =36mm |
| DGC/34M | 34mm Medium | Height 'A' =25mm |
| DGC/34H | 34mm High | Height 'A' =29mm |
| DGC/34EH | 34mm Extra High | Height 'A' =36mm |

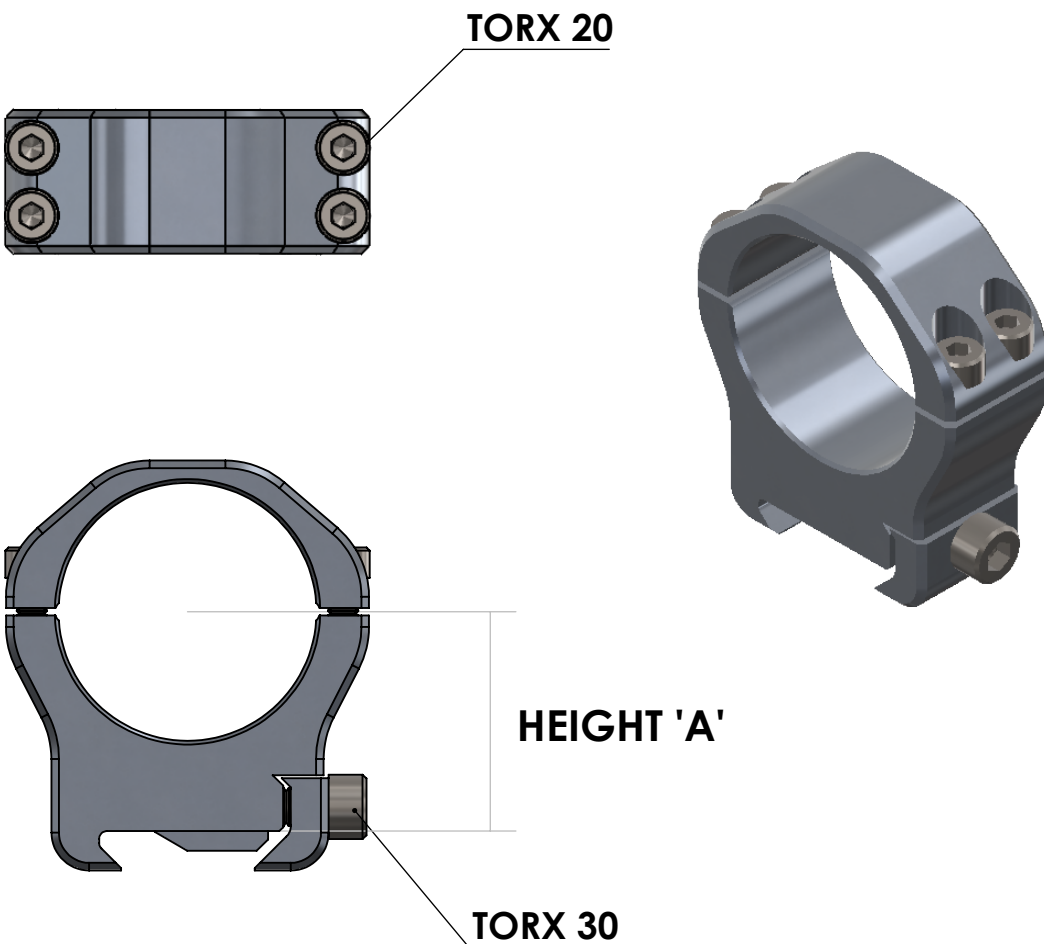

| TORQUE SETTINGS | In/lb | Nm |
|-----------------|-------|-----|
| TORX 20 | 25 | 2.8 |
| TORX 30 | 45 | 5.0 |

| | | | | | | | | | | | |
|---|--|--|---|--|------------------------------------|---|----------------------|--|-------------|--|--|
| UNLESS OTHERWISE SPECIFIED: DIMENSIONS ARE IN MILLIMETERS SURFACE FINISH: TOLERANCES: LINEAR: ANGULAR: | | | FINISH: HARD ANODISE 40 MICRONS BLACK OR SILVER | | DEBURR AND BREAK SHARP EDGES | | DO NOT SCALE DRAWING | | REVISION 01 | | |
| DRAWN: AB | | | | | | TITLE: Picatinny Scope Ring Heights | | | | | |
| SIGNATURE | | | | | | MATERIAL: AL6082 T6 | | | | | |
| DATE: 06/03/19 | | | | | | DWG NO. | | | | | |
| MFG | | | | | | SCALE:1:1 | | | | | |
| Q.A | | | | | | SHEET 1 OF 1 | | | | | |

4

3

2

1

A4

F

F

E

E

D

D

C

C

B

B

A

A